

Elastomerkupplung WKE-ND - spielfrei

Elastomer Coupling WKE-ND - backlash-free

mit Spreizdorn / with expanding mandrel

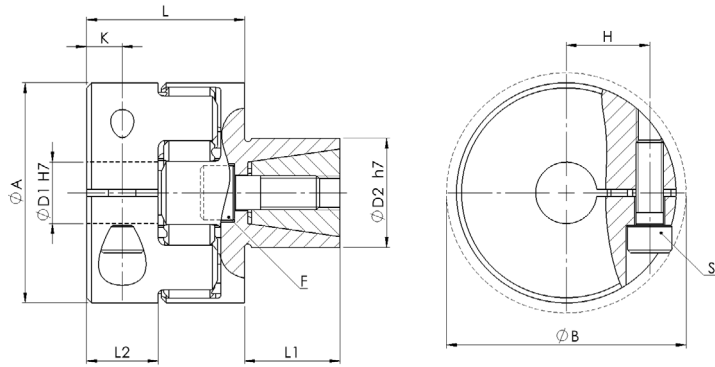

Material:

Nabe - Aluminium

Standardzahnkranz:

98 ShA

Optional Zahnkranz:

64 ShD, 80 ShA, 92 ShA

Optional Passfedernut ØD1:

Nach DIN 6885

Material:

Hub - aluminum

Standard elastomer insert:

98 ShA

Optional elastomer insert:

64 ShD, 80 ShA, 92 ShA

Optional Keyway ØD1:

Acc. to DIN 6885

WKE-ND			Abmessungen Dimensions									ISO 4762		Technische Daten Technical Data				
Größe Size	TKN		L	ØA	ØD1	ØD2	L1	L2	ØB	K	H	S	F	TA	TA	J	n_{max}	M
	98 ShA	92 ShA												(S)	(F)	[Nm]	[Nm]	[kg cm ²]
	[Nm]		[mm]															
9	5	3	20	20	5 - 11	10 - 16	12	7	23	3,5	7,3	M2,5	M4	1,3	5	0,01	18000	0,03
14	12,5	7,5	28,5	30	6 - 16	13 - 25	12,5	9,5	32	5	11	M3	M5	2	11	0,07	12000	0,06
19	17	10	42	40	8 - 24	14 - 30	20	17	45	8,5	15,5	M5	M6	11	19	0,28	9500	0,013
24	60	35	46	55	10 - 32	23 - 38	30	20	57	10	20	M6	M8	19	42	1,13	7000	0,33
28	160	95	48	65	15 - 38	26 - 42	36	21	70,5	10,5	24,5	M8	M10	42	83	2,22	6000	0,5
38	325	190	69	80	15 - 45	38 - 60	45	31	85	15,5	30	M10	M12	83	145	8,03	4700	1,1

Massenträgheitsmoment und Masse sind mit dem größten Bohrungsdurchmesser gerechnet. Mass moment of inertia and mass are calculated with reference to the largest bore size.

Weitere technische Daten, siehe Seite 33. Further technical data, see page 33.

Laufend aktualisierte Daten finden Sie auf unserer Homepage. For continuously updated data please refer to our website.

Technische Daten

- TKN - Drehmoment
- TA - Anzugs-Drehmoment der Schraube
- J - Massenträgheitsmoment
- n_{max} - max. Drehzahl
- M - Masse

Technical Data

- TKN - Torque
- TA - Installation torque per screw
- J - Mass moment of inertia
- n_{max} - max. speed
- M - Mass

Bestellbeispiel / order example	WKE-ND	19	12	20	98	SX
Modell / model						
Größe / size						
Bohrung ØD1 H7 / bore ØD1 H7						
Bohrung ØD2 h7 / bore ØD2 h7						
Zahnkranz / elastomer insert						
Sonderoption / special option						



Achsversätze Offset

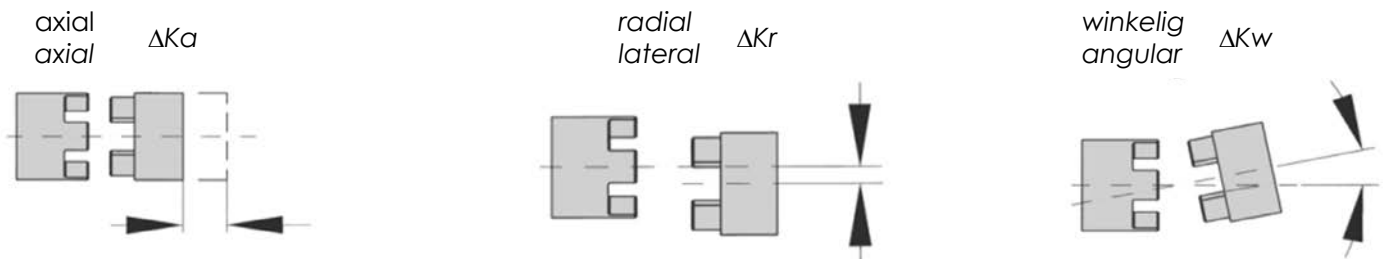

Eigenschaften der Zahnkränze Characteristics of the elastomer inserts



92 Shore A

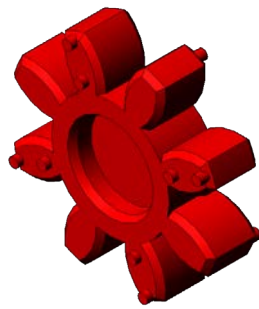

98 Shore A

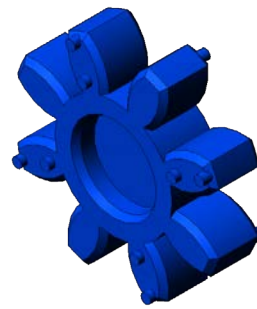

80 Shore A



64 Shore D

Shorehärte Shore hardness	Farbe Color	Größe Size	Material Material	Temperaturbereich Temperature range	Eigenschaften Features
92 Shore A	gelb yellow	5 - 65	PUR	-40 °C to +90 °C	Gute Dämpfung High damping
98 Shore A	rot red	5 - 55	PUR	-30 °C to +90 °C	Gute Dämpfung High damping
80 Shore A	blau blue	5 - 19	PUR	-50 °C to +80 °C	Sehr gute Dämpfung Very high damping
64 Shore D	grün green	7 - 65	Hytrel	-40 °C to +120 °C	Hohe Torsionssteife High torsional stiffness

Technische Daten

Technical Data

Größe Size	Shorehärte Shore hardness	Drehfedersteife Torsional spring stiffness			Versatz Misalignment			Drehmoment Torque
		CT _{stat.} *	CT _{dyn.} *	CR	ΔKa	ΔKr	ΔKw	
		[Nm/rad]			[mm]		[°]	
5	80 Sh A	3,1	10	82	+0,4 -0,2	0,12	1,1	0,3
	92 Sh A	5,1	16	154		0,06	1	0,5
	98 Sh A	8,3	25	296		0,04	0,9	0,9
7	80 Sh A	8,6	26	114	+0,6 -0,3	0,15	1,1	0,7
	92 Sh A	14,3	43	219		0,1	1	1,2
	98 Sh A	22,9	69	421		0,06	0,9	2
	64 Sh D	34,3	103	630		0,04	0,8	2,4
9	80 Sh A	17,2	52	125	+0,8 -0,4	0,19	1,1	1,8
	92 Sh A	31,5	95	262		0,13	1	3
	98 Sh A	51,6	155	518		0,08	0,9	5
	64 Sh D	74,6	224	739		0,05	0,8	6
14	80 Sh A	60,2	180	153	+1,0 -0,5	0,21	1,1	4
	92 Sh A	114,6	344	335		0,15	1	7,5
	98 Sh A	171,9	513	655		0,09	0,9	12,5
	64 Sh D	234,2	702	855		0,06	0,8	16
19	80 Sh A	618	1.065	582	+1,2 -0,5	0,15	1,1	5
	92 Sh A	1.090	1.815	1.120		0,1	1	10
	98 Sh A	1.512	2.540	2.010		0,06	0,9	17
	64 Sh D	2.560	3.810	2.930		0,04	0,8	21
24	92 Sh A	2.280	4.010	1.480	+1,4 -0,5	0,14	1	35
	98 Sh A	3.640	5.980	2.560		0,1	0,9	60
	64 Sh D	5.030	10.896	3.696		0,07	0,8	75
28	92 Sh A	4.080	6.745	1.780	+1,5 -0,7	0,15	1	95
	98 Sh A	6.410	9.920	3.200		0,11	0,9	160
	64 Sh D	10.260	20.177	4.348		0,08	0,8	200
38	92 Sh A	6.525	11.050	2.350	+1,8 -0,7	0,17	1	190
	98 Sh A	11.800	17.160	4.400		0,12	0,9	325
	64 Sh D	26.300	40.335	6.474		0,09	0,8	405
42	92 Sh A	10.870	15.680	2.430	+2,0 -1,0	0,19	1	265
	98 Sh A	21.594	37.692	5.570		0,14	0,9	450
	64 Sh D	36.860	69.825	7.270		0,1	0,8	560
48	92 Sh A	12.968	18.400	2.580	+2,1 -1,0	0,23	1	310
	98 Sh A	25.759	45.620	5.930		0,16	0,9	525
	64 Sh D	57.630	99.750	8.274		0,11	0,8	655
55	92 Sh A	15.482	21.375	2.980	+2,2 -1,0	0,24	1	410
	98 Sh A	42.117	61.550	6.686		0,17	0,9	685
	64 Sh D	105.730	130.200	9.248		0,12	0,8	825
65	98 Sh A	48.520	71.660	6.418	+2,6 -1,0	0,18	0,9	940
	64 Sh A	118.500	189.190	8.870		0,13	0,8	1175

*Statische und dynamische Drehfedersteifigkeit bei 0,5x TKN

*statical and dynamical torsional spring stiffness at 0,5xTKN

Technische Daten

CT_{stat.} - Statistische Drehfedersteife
 CT_{dyn.} - Dynamische Drehfedersteife
 CR - Radiale Federsteife
 ΔKa - Axialer Versatz
 ΔKr - Radialer Versatz
 ΔKw - Winkeliger Versatz

Technical Data

CT_{stat.} - Statistical torsional spring stiffness
 CT_{dyn.} - Dynamical torsional spring stiffness
 CR - Radial spring stiffness
 ΔKa - Axial misalignment
 ΔKr - Lateral misalignment
 ΔKw - Angular misalignment