

Acoplamiento de eje intermedio ZWK4

Intermediate Shaft Coupling ZWK4

con cubo de apriete - versión de fuelle metálico / with clamping hub - metal bellow version

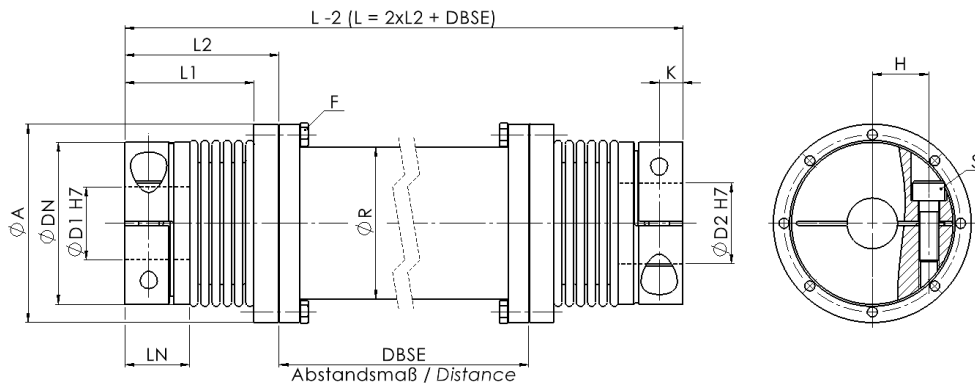

Material:

Fuelle - Acero inox
Cubo - Aluminio
Eje intermedio - Aluminio

Rango de temperatura:

-30 °C a +120 °C

Chavetero opcional ØD1 / ØD2:

Según DIN 6885

Material:

Bellow - stainless steel
Hub - aluminum
Intermediate tube - aluminum

Temperature range:

-30 °C to +120 °C

Optional keyway ØD1 / ØD2:

Acc. to DIN 6885

ZWK4		Dimensiones Dimensions										ISO 4762	ISO 4017	Datos Técnicos Technical Data		
Tamaño Size	TKN [Nm]	L	ØA	ØDN	ØD1 / ØD2	LN	L1	L2	ØR	K	H	S	F	TA (S) [Nm]	TA (F) [Nm]	CT [Nm/rad]
18	22	140 - 3000	60	45	8 - 25,4	20,5	44	53	40	5,75	17,5	M5	4x M4	11	5	4006
30	36	145 - 3000	70	54	10 - 30	24,5	41,5	57,5	50	7,5	20	M6	6x M4	19	5	9781
60	75	190 - 3000	85	65	12 - 35	29	50	71	60	10	24	M8	6x M5	42	11	22600
150	180	210 - 3000	98	79	14 - 42	34	57,5	70	75	11,75	28	M10	8x M6	83	19	47169
200	240	220 - 3000	120	90	20 - 45	38	62,5	74,5	90	12,5	31,5	M12	8x M6	145	19	75797
300	360	230 - 3000	135	109	24 - 60	38	65	79	100	13	39	M12	8x M8	145	42	160700
500	600	250 - 3000	148	119	35 - 62	41,5	70,5	84,5	100	14,25	42	M14	8x M8	255	42	240740

Para más datos técnicos, véase la página 41. Further technical data, see page 41.

Para datos siempre actualizados, diríjase a nuestra página web. For continuously updated data please refer to our website.

Datos Técnicos

TKN - Par
TA - Par de apriete por tornillo
CT - Rigidez torsional

Technical Data

TKN - Torque
TA - Installation torque per screw
CT - Torsional stiffness

Ejemplo de pedido / order example	ZWK4	30	800	25	20	SX
Modelo / model						
Tamaño / size						
Longitud / length						
Eje ØD1 H7 / bore ØD1 H7						
Eje ØD2 H7 / bore ØD2 H7						
Opción especial / special option						



Acoplamiento de eje intermedio ZWK

Intermediate Shaft Coupling ZWK

Información General / General Information

Desalineación - versión de fuelle metálico

Offset – metal bellow version

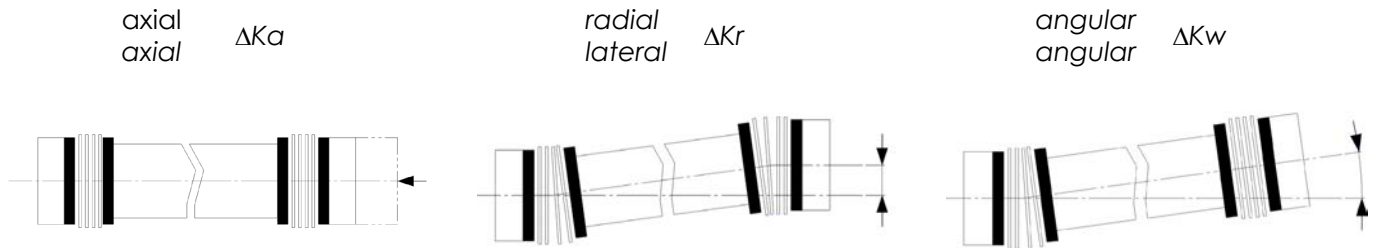

Tamaño Size	Rigidez torsional Torsional spring stiffness		Desalineación Misalignment			Par Torque
	CT	ΔK_a	ΔK_r	ΔK_w	En función de la longitud del tubo intermedio Depending on the intermediate shaft length	
	[Nm/rad]	[mm]	[mm]	[°]		
10	3521	2	En función de la longitud del tubo intermedio Depending on the intermediate shaft length	2x 1	10	
18	4006	2		2x 1	22	
30	9781	2		2x 1	36	
60	22600	3		2x 1	75	
150	47169	4		2x 1	180	
200	75797	4		2x 1	240	
300	160700	4		2x 1	360	
500	240740	5		2x 1	600	

Desalineación - versión elastomérica

Offset – elastomer version

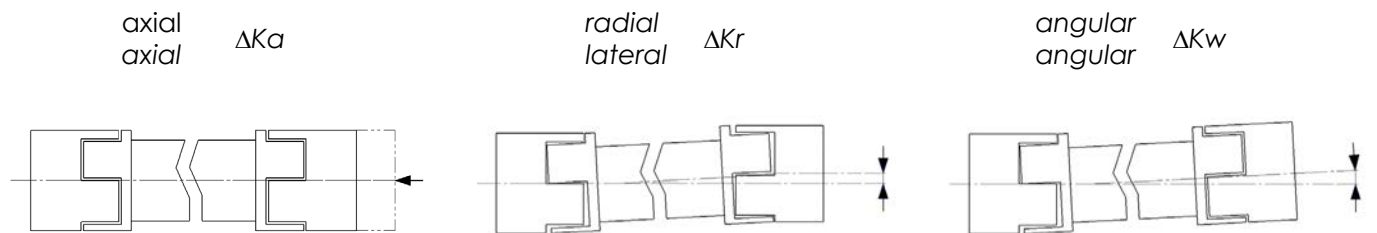

Tamaño Size	Rigidez torsional Torsional spring stiffness		Desalineación Misalignment			Par Torque
	CT ZWKE-N	CT ZWKE-HR	ΔK_a	ΔK_r	ΔK_w	
	[Nm/rad]		CT	[mm]	[°]	
14	510	730	± 2	En función de la longitud del tubo intermedio Depending on the intermediate shaft length	2	12,5
19	966	1775	± 2		2	17
24	2635	6450	± 2		2	60
28	5549	11500	± 2		2	160
38	15250	24000	± 2		2	325
42	15250	58000	± 2		2	450
48	42050	73000	± 2		2	525