

Inner and outer rings are pre-loaded axially

Conditions for most favourable effect

The effect of axial pre-loading depends on certain conditions:

- The axial pressure must be applied to the whole outer race.
- Axial variations and length tolerances within the components of the machine should have only the very slightest effect on the applied spring force.
- The axial pre-loading must be done with a load suitably adapted to the size of the bearing.

Protection of Bearings subject to vibration when non-rotating

The spring axial location also eliminates damage as a result of vibration in non-rotating bearings. This type of damage is well known in electric motors for auxiliary drives in ships and vehicles. If the auxiliary drives is stationary, the rotor can vibrate in the bearing, due to the vibration of the ship or vehicle. In these conditions the balls beat in the races of the bearing rings and cause wear. This is why leading manufacturers use only ball bearings, the radial play of which is removed by Star Spring Washers, so preventing any vibration of the rotor. The reason for damage is then completely eliminated.

Features

- RINGSPANN Star Spring Washers are particularly light spring elements with linear or not-linear spring characteristic. They are suitable for application as pressure elements in precision machines and as pressure springs for taking up free movement, and for reducing noise in ball bearings.
- The very large axial movement of the spring guarantees that considerable axial variations and length tolerances can be accommodated without much deviation from the nominal value of the axial force of the Star Spring Washer.
- Because of the large axial variations of the spring it is often possible to achieve the desired effect with a single Star Spring Washer.
- Their spring load corresponds with the optimum values of the relevant bearing sizes.

Service Life

Ball bearings give longer service if the inner and outer rings are pre-loaded axially (figure 88-2). This fact has been known for a long time. This axial preloading by RINGSPANN Star Spring Washers eliminates radial play in the ball bearings. This effects a better distribution of the radial load to be transmitted onto the bearing rings and therefore increases the length of service life of the bearing.

Silent Running

High speed machines, particularly small electric motors, create special problems for the designer regarding silent running. Extensive trials in this field have shown, that in the main, noise originates in the ball bearings, and that the application of the exact amount of axial pressure suitable for each job reducing noise effectively.

as ball bearing compensating discs for taking up free movement in bearings

Bearing of an internal grinding spindle

Spindle ball bearings are used as bearing support for grinding spindles. Bearings of this kind exhibit maximum tracking accuracy at high rotation speeds.

The specific properties of these bearings can be fully exploited only if the bearings are pre-clamped with a precisely defined force.

RINGSPANN Star Springs Washers enable you to realise the required pre-clamping force of the spindle bearings with a high degree of precision.

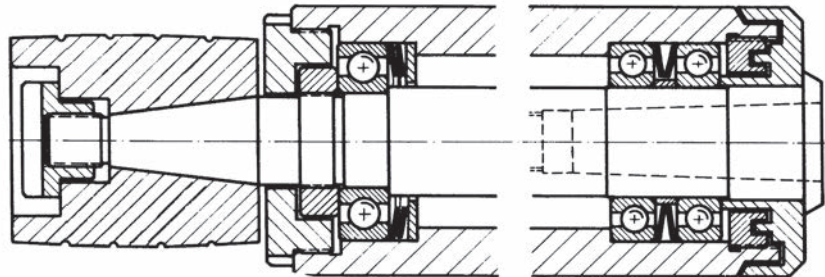

Bearing of an internal grinding spindle

89-1

Pressure spring for ball bearing

Silent running is a particular requirement for electric motors. For this purpose a RINGSPANN Star Spring Washer acts to pre-load the outer race of the bearing as illustrated.

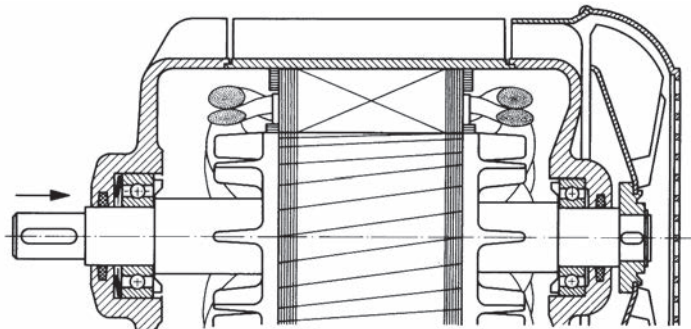

Pressure spring for ball bearing

89-2

Accommodating length tolerances

As shown in this example the RINGSPANN Star Spring Washer fitted between output shaft and NILOS sealing ring makes it possible to accommodate wide axial tolerances.

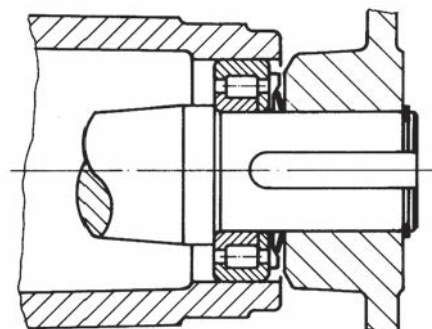

Accommodating length tolerances

89-3

as ball bearing compensating discs for taking up free movement in bearings

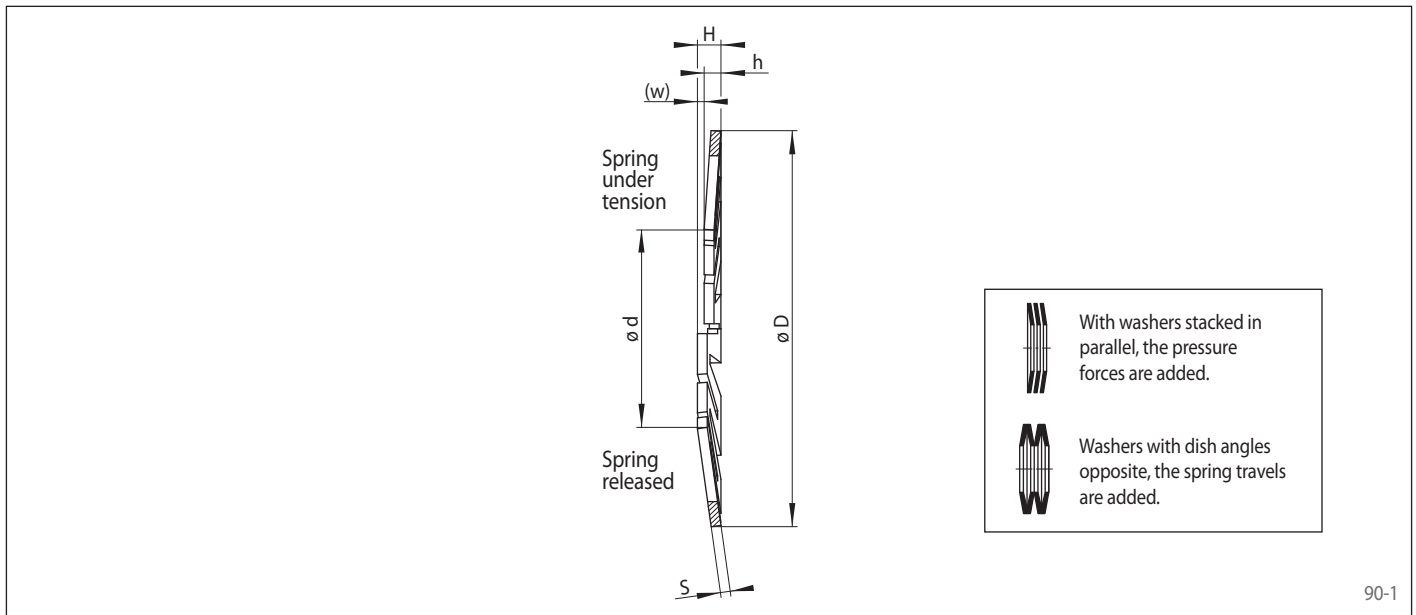

90-1

For ball bearing					Dimension			Height		Tolerance for h	Spring travel	Pressure	Spring const.	Article number
					D mm	d mm	s mm	released H mm	under pressure h mm	mm	(w) mm	F N	c N/mm	1051-
				624	12,7	5,3	0,3	1,1	0,7	± 0,15	0,4	14	35	012001
634	E 3	E 4	E 5	625	15,7	7,5	0,3	1,1	0,7	± 0,15	0,4	9	23	015001
635			626	607	18,7	7,5	0,3	1,4	0,7	± 0,15	0,7	10	14	018001
635			626	607	18,7	9,2	0,3	1,2	0,7	± 0,15	0,5	11	22	018002
	E 6				20,7	10,5	0,3	1,3	0,7	± 0,15	0,6	7	12	020001
627	E 7			608	21,7	11	0,5	1,6	0,9	± 0,15	0,7	34	49	021001
	E 8			609	23,7	11	0,5	1,8	1,0	± 0,2	0,8	33	41	023001
629			6000		25,7	11	0,5	2,0	1,0	± 0,2	1,0	31	31	025001
629			6000		25,7	13,5	0,5	1,7	1,0	± 0,2	0,7	30	43	025002
16100	E 9	E 10	6001		27,7	15	0,65	1,9	1,1	± 0,2	0,8	52	65	027001
16101	E 13			6200	29,7	15	0,65	2,1	1,1	± 0,21	1,0	38	38	029001
	E 11	E 12		6201	31,7	15	0,65	2,3	1,1	± 0,2	1,2	46	38	031001
16002			6002	6201	31,7	18	0,65	2,0	1,1	± 0,21	0,9	36	40	031002
16003	E 14	E 15	6003	6202	34,7	20	0,9	2,4	1,4	± 0,2	1,0	89	89	034001
					36,7	20	0,9	2,6	1,4	± 0,21	1,2	92	77	036001
	E 16				37,7	20	0,9	2,7	1,4	± 0,2	1,3	84	65	037001
	E 19	L 17a	Bo 15	6203	39,7	20	0,9	2,9	1,4	± 0,2	1,5	81	54	039001
	E 19			6203	39,7	23	0,9	2,6	1,4	± 0,2	1,2	103	86	039002
16004			6004	6302	41,7	27	0,9	2,4	1,4	± 0,2	1,0	76	76	041001
		EA 17	Bo 17		43,5	27	0,9	2,6	1,4	± 0,2	1,2	68	57	043001
16005	E 20	L 20	6005	6204	46,5	27	0,9	2,9	1,4	± 0,2	1,5	74	49	046001
16005			6005		46,5	30	0,9	2,6	1,4	± 0,2	1,2	72	60	046002
	M 20	L 25	6205	6304	51,5	35	0,9	2,6	1,4	± 0,2	1,2	61	51	051001
16006			6006		54,5	35	1,15	3,1	1,7	± 0,25	1,4	98	70	054001
16007	L 30	6007	6206	6305	6403	61	40	1,15	3,3	± 0,25	1,6	110	69	061001
16008		6008			67	45	1,15	3,4	1,7	± 0,25	1,7	90	53	067001
			6207	6306	6404	71	45	1,15	3,8	± 0,25	2,1	110	52	071001
16009		6009			74	50	1,15	3,6	1,7	± 0,25	1,9	130	68	074001

Mounting

Generally it will be found most suitable for the Star Spring Washer to work on the outer ring of the ball bearing. The Star Spring Washer outside diameters given in the following table correspond therefore with the ball bearing outside diameters. The RINGSPANN design with slots

and dished shape guarantees even axial pressure on the whole outer race. If an axial pressure is applied to the shaft in one direction only, the Star Spring Washer must be mounted in such a way that there is no axial pressure on it (figure 89-2). If the axial pressures vary or are in both di-

rections, a Star Spring Washer has to be mounted both sides of the ball bearings. In this case and in any doubtful cases we will be pleased to submit an installation proposal.

as ball bearing compensating discs for taking up free movement in bearings

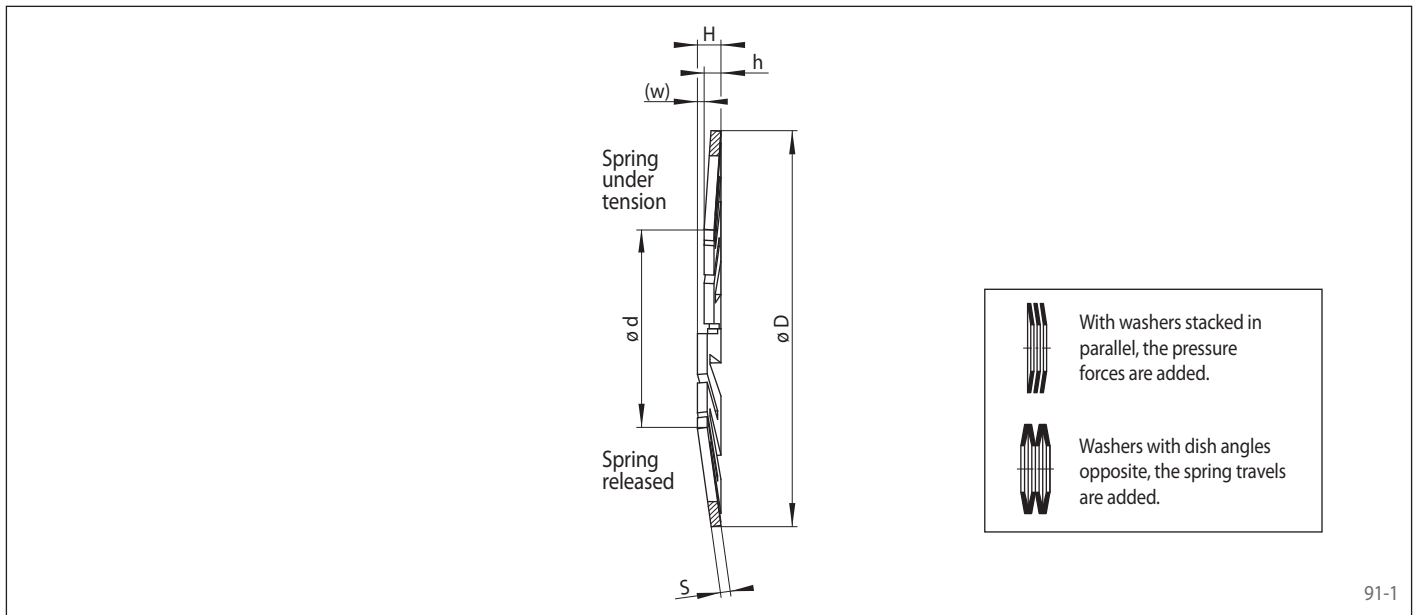

91-1

For ball bearing					Dimension			Height		Tolerance for h	Spring travel	Pressure	Spring const.	Article number
					D mm	d mm	s mm	released H mm	under pressure h mm					
16010	6010	6208	6307	6405	79	58	1,15	3,3	1,7	± 0,25	1,6	290	Diminishing spring characteristic	079001
		6209			84	63	1,15	3,3	1,7	± 0,25	1,6	320		084001
16011	6011	6210	6308	6406	89	63	1,15	3,8	1,7	± 0,25	2,1	290		089001
16012	6012				94	68	1,15	3,8	1,9	± 0,4	1,9	260		094001
16013	6013	6211	6309	6407	99	73	1,15	3,8	1,9	± 0,4	1,9	280		099001
16014	6014	6212	6310	6408	109	78	1,15	4,2	2,0	± 0,4	2,2	180		109001
16015	6015				114	83	1,15	4,2	2,0	± 0,4	2,2	200		114001
		6213	6311	6409	119	88	1,15	4,2	2,0	± 0,4	2,2	270		119001
16016	6016	6214			124	93	1,15	4,2	2,0	± 0,4	2,2	250		124001
16017	6017	6215	6312	6410	129	98	1,15	4,2	2,0	± 0,4	2,2	250		129001
16018	6018	6216	6313	6411	139	98	1,25	5,3	2,3	± 0,5	3,0	330		139001
16019	6019				144	103	1,25	5,3	2,3	± 0,5	3,0	330		144001
16020	6020	6217	6314	6412	149	108	1,25	5,3	2,3	± 0,5	3,0	370		149001
16021	6021	6218	6315	6413	158	118	1,5	5,5	2,5	± 0,5	3,0	410		158001
16022	6022	6219	6316		168	123	1,5	6	2,7	± 0,5	3,3	470		168001
16024	6024	6220	6317	6414	178	133	1,5	6	2,7	± 0,5	3,3	600		178001
		6221	6318	6415	188	138	2,1	7	3,3	± 0,5	3,7	520		188001
16026	6026	6222	6319	6416	198	143	2	7,5	3,3	± 0,5	4,2	660		198001
16028	6028			6417	208	163	2	6,2	3,0	± 0,5	3,2	1160		208001
		6224	6320		213	168	2	6,4	3,1	± 0,5	3,3	1120		213001
16030	6030		6321	6418	223	183	2	6,1	3,0	± 0,5	3,1	1200		223001
		6226			228	188	2	6,2	3,0	± 0,5	3,2	1160		228001
16032	6032		6322		238	198	2	6,4	3,1	± 0,5	3,3	1120		238001
		6228			248	211	2	6,2	3,0	± 0,5	3,2	1160		248001
16034	6034		6324		258	223	2	6,2	3,0	± 0,5	3,2	1180		258001

Explanation concerning the table

Apart from the listed ball bearing series the Star Spring Washers can also be used for series 32, 33, 42, 72 and 73. Pressure F is attained at height h. The spring constant c, i.e. the pressure increase per mm spring travel can only be given up to size 74 x 50 x 1,15.

With larger Star Spring Washers the spring characteristic is not linear but diminishing. With tolerances of the installation height h the pressure F therefore changes even less than with smaller washers.

Example for ordering

Star Spring Washer for ball bearings of series 16011:

- Article number 1052-089001