



## MULTI CROSS RILLO

Highly Flexible Tyre Coupling with Taper Bushes

[www.reich-kupplungen.com](http://www.reich-kupplungen.com)



SIMPLY **POWERFUL.**



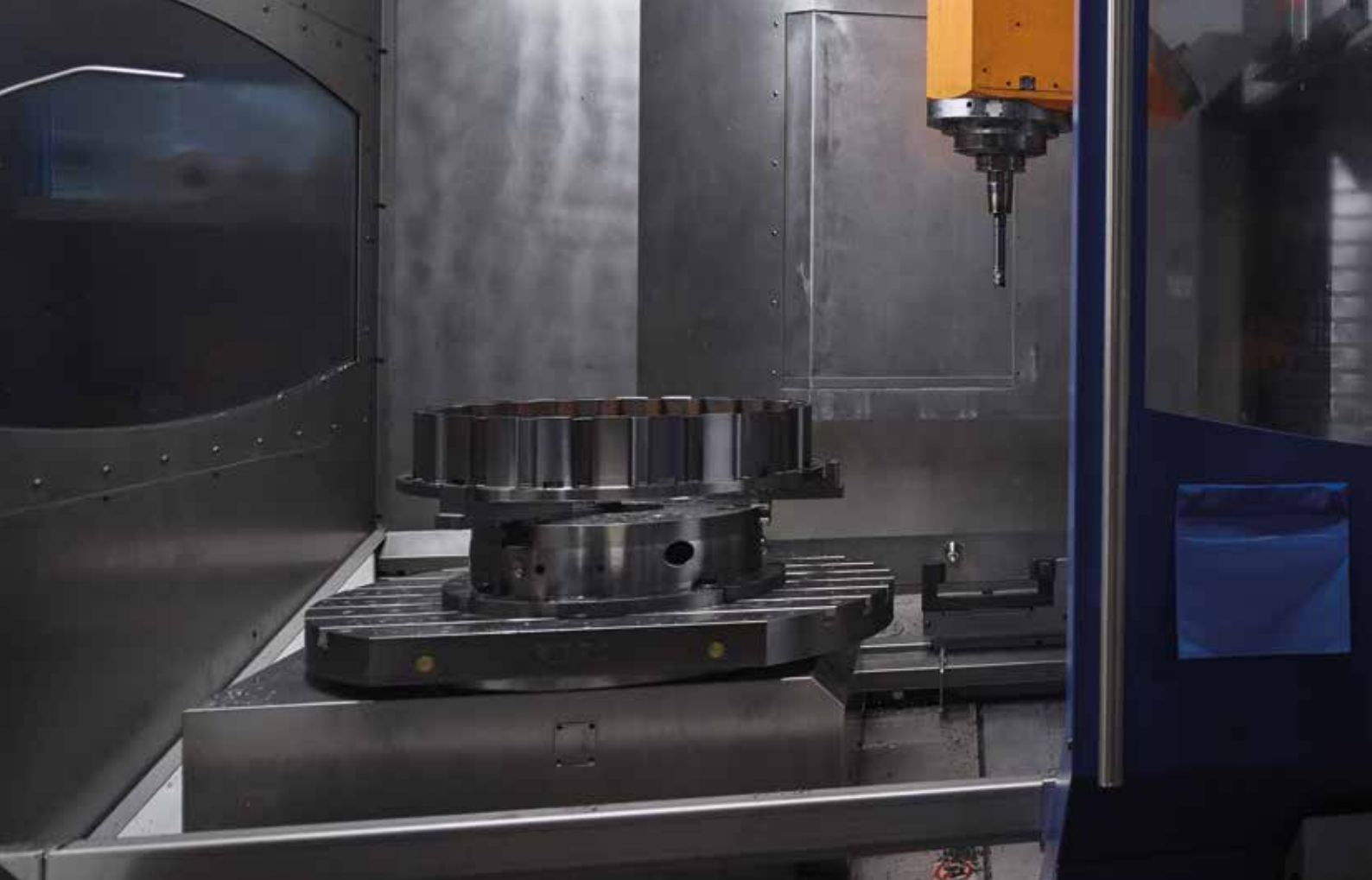

## D2C – Designed to Customer

The guiding principle of Designed to Customer is the recipe for success behind REICH. In addition to the catalogue products, we supply our customers with couplings developed to their specific requirements. The designs are mainly based on modular components to provide effective and efficient customer solutions. The special nature of our close cooperation with our partners ranges from; consulting, development, design, manufacture and integration to existing environments, to customer-specific production, logistics concepts and after-sales service - worldwide.

This customer-oriented concept applies to both standard products and production in small batch sizes.

The company policy at REICH embraces, first and foremost, principles such as customer satisfaction, flexibility, quality, prompt delivery and adaptability to the requirements of our customers.

REICH provides you with not only a coupling, but a solution:

Designed to Customer – SIMPLY **POWERFUL**.

**D2C**  
Designed to Customer



# MULTI CROSS RILLO

## Contents

### Coupling Information

- 04** General Technical Description

---

- 05** Advantages

---

- 06** Standard Types

---

- 08** General Technical Data

---

- 09** Technical Layout

---

- 10** Selection of the Coupling Size

---

- 12** Assignment to IEC Standard Motors

---

- 13** Power Ratings

---

- 18** Ordering Information

---

- 19** Permissible Shaft Displacement

---

- 20** Data Required for Coupling Size Selection

### Dimension Tables

- 14** Shaft Coupling

---

- 16** Coupling with Spacer

# MULTI CROSS RILLO

## General Technical Description

### MULTI CROSS RILLO

## Highly Flexible Tyre Coupling with Taper Bushes

The MULTI CROSS RILLO (short form: MCR) are highly torsionally flexible tyre couplings with progressive torsional deflection characteristic. The salient feature of the MULTI CROSS RILLO shaft couplings is that the coupling hubs are supplied with commercially available taper bushes for nominal torques of up to 14 675 Nm. This allows easy and time saving mounting of the coupling hubs on the shaft. Special tools are not required.

The torque transmission element of the MULTI CROSS RILLO coupling is a rubber tyre reinforced with fabric plies. This tyre transmits the torque without torsional backlash, it is wear-resistant and maintenance-free. The rubber tyre is slotted to allow easy radial mounting without axial displacement of the coupled machines.

MULTI CROSS RILLO shaft couplings reduce torque surges substantially. The high torsional flexibility has a particularly beneficial effect in systems where torsional vibrations occur creating stresses in the drive train.

The use of a rubber tyre as the transmission element compensates to a large extent for axial, radial and angular shaft displacements.



## MULTI CROSS RILLO

Nominal torques from 24 Nm to 14 675 Nm

## MULTI CROSS RILLO

### Advantages

**Salient features and advantages of the MULTI CROSS RILLO coupling:**

- High torsional flexibility with progressive torsional deflection characteristic
- High compensating capability for axial, radial and angular displacements
- Easy and time saving mounting of the coupling hubs thanks to the use of taper bushes
- Radial change of the rubber element without axial movement of the coupled machines
- Backlash-free torque transmission even in case of alternating directions of rotation
- High torsional vibration and shock load damping capability
- Body soundproofing
- Wear-resistant and maintenance-free

# MULTI CROSS RILLO

## Standard Types

Sizes MCR 40 to 60

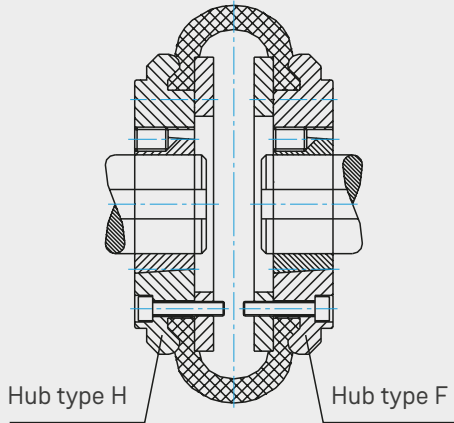

### Shaft couplings with taper bushes

$T_{KN} = 24$  bis 127 Nm

Hub type H: Taper bush connection from outside

Hub type F: Taper bush connection from inside

Sizes MCR 70 to 220

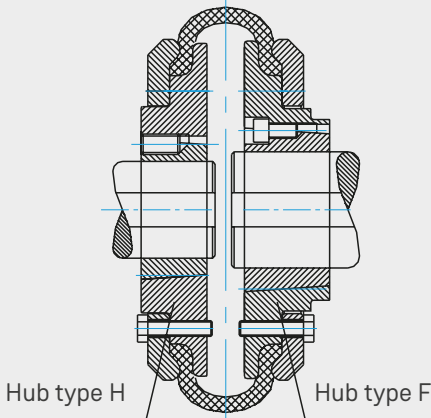

### Shaft couplings with taper bushes

$T_{KN} = 250$  bis 11600 Nm

Hub type H: Taper bush connection from outside

Hub type F: Taper bush connection from inside

Sizes MCR 40 to 60

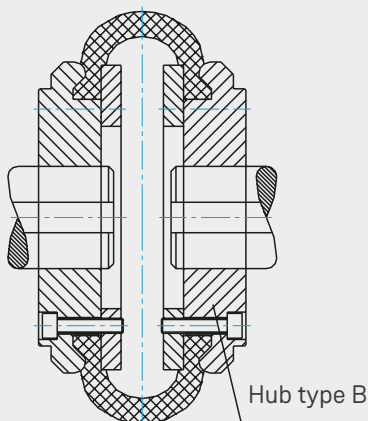

### Shaft couplings

$T_{KN} = 24$  bis 127 Nm

Hub type B: without taper bush

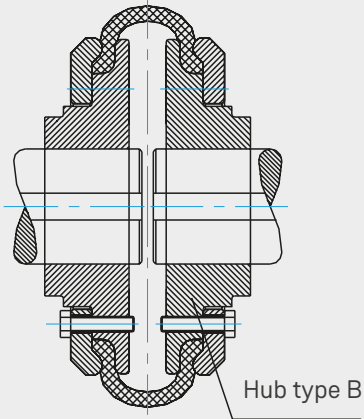

### Shaft couplings

$T_{KN} = 250$  bis 14 675 Nm

Hub type B: without taper bush

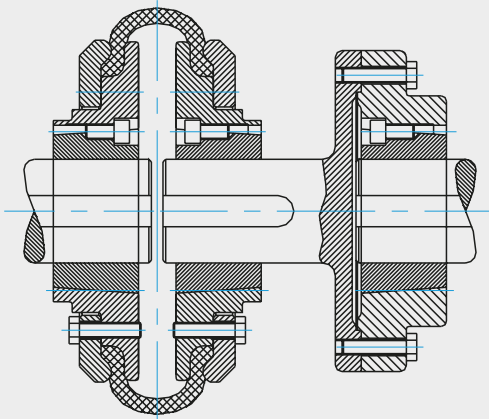

### Couplings with spacers

$T_{KN} = 24$  bis 2 325 Nm

The flange hub is also available without taper bush on request.

# MULTI CROSS RILLO

## General Technical Data



### Standard Type

Coupling size	Nominal torque $T_{KN}$ [Nm]	Maximum torque $T_{K \max}$ [Nm]	Continuous fatigue torque $T_{KW} (10 \text{ Hz})$ [Nm]	Dynamic torsional stiffness $C_{T \text{ dyn}}$ [Nm/rad]	Relative damping $\Psi$ -	Maximum speed $n_{\max}$ [min <sup>-1</sup> ]	Permissible shaft displacement <sup>1)</sup>		
							Axial $\Delta K_a$ [mm]	Radial $\Delta K_r$ [mm]	Angular $\Delta K_w$ [mm]
MCR 40	24	60	10	285	0.9	4500	1.3	1.0	5.7
MCR 50	66	160	25	745	0.9	4500	1.7	1.3	7.0
MCR 60	127	330	50	1500	0.9	4000	2.0	1.6	8.7
MCR 70	250	490	100	2350	0.9	3600	2.3	1.9	10.0
MCR 80	375	750	150	3600	0.9	3100	2.6	2.1	12.0
MCR 90	500	1100	200	5200	0.9	3000	3.0	2.4	13.0
MCR 100	675	1510	270	7200	0.9	2600	3.3	2.6	15.0
MCR 110	875	2140	350	10000	0.9	2300	3.7	2.9	16.0
MCR 120	1330	3500	530	17000	0.9	2050	4.0	3.2	18.0
MCR 140	2325	5600	930	28000	0.9	1800	4.6	3.7	22.0
MCR 160	3770	9280	1500	44500	0.9	1600	5.3	4.2	24.0
MCR 180	6270	16420	2500	78500	0.9	1500	6.0	4.8	28.0
MCR 200	9325	23560	3700	110000	0.9	1300	6.6	5.3	30.0
MCR 220	11600	33300	4600	160000	0.9	1100	7.3	5.8	33.0
MCR 250	14675	43000	5800	200000	0.9	1000	8.2	6.6	37.0

<sup>1)</sup> See explanation on page 18

### Technical Note

The technical data applies only to the complete coupling or the corresponding coupling elements. It is the customer's/user's responsibility to ensure there are no inadmissible loads acting on any of the components. In particular, existing connections, e.g. bolted connections, must be checked with regard to the torques to be transmitted. If necessary, further measures, such as additional reinforcement with pins, may be necessary. It is the customer's/user's responsibility to make sure the dimensioning of the shaft and keyed or other connection, e.g. shrinking or clamping connection,

is correct. All components that can rust are protected against corrosion as standard.

REICH have an extensive range of couplings and coupling systems to cover nearly every drive configuration. Customized solutions can be developed and manufactured even in small batches or as prototypes. In addition calculation programs are available for all necessary dimensioning.



# MULTI CROSS RILLO

## Technical Layout

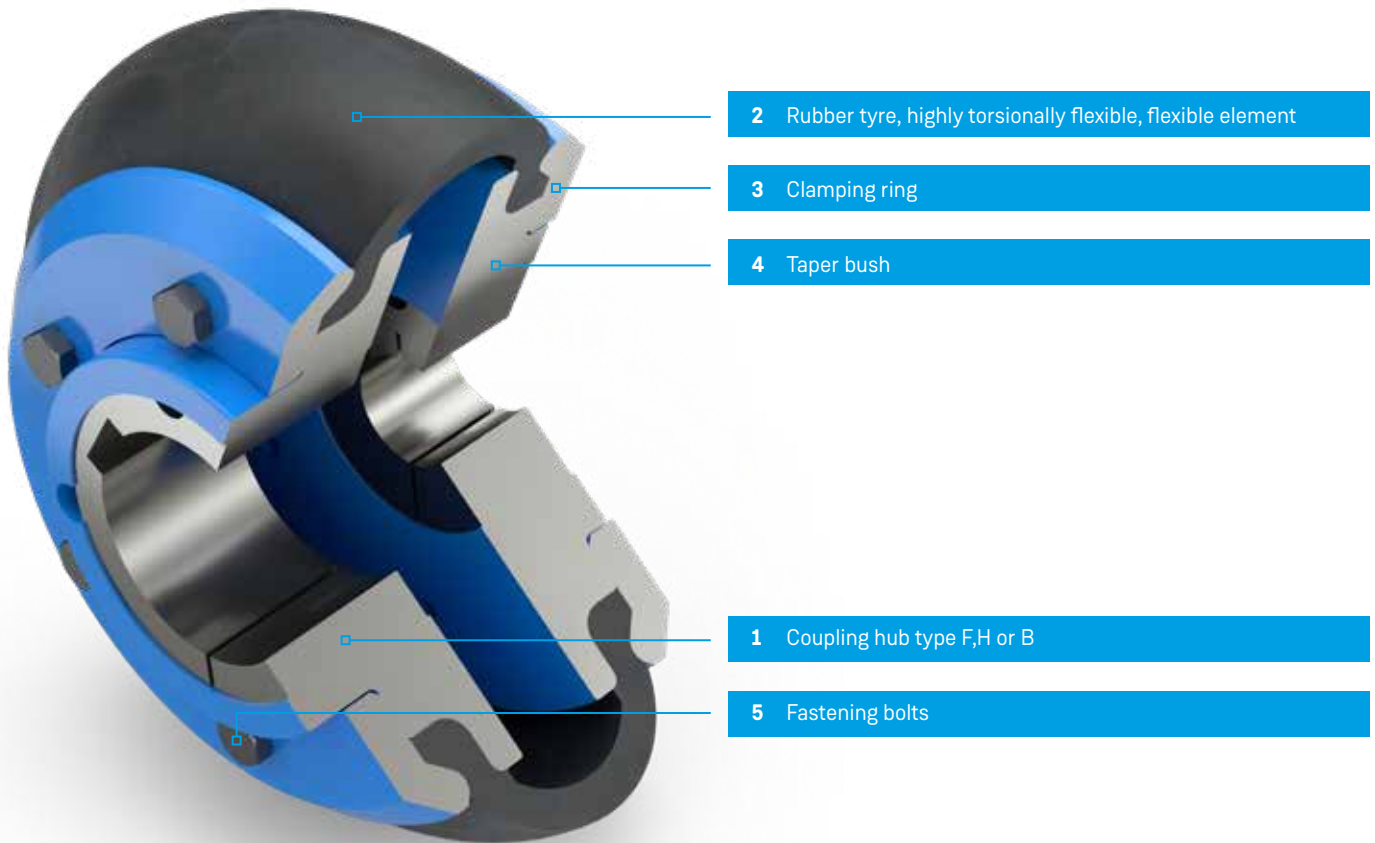

**i** MULTI CROSS RILLO tyre couplings have no fail safe device.

### Material Overview

Part No.	Designation	Materials
1	Coupling hub	Spheroidal cast iron
2	Rubber tyre	a) Standard version: Natural caoutchouc tyre b) Flame-resistant and antistatic: Chloroprene tyre
3	Clamp ring	Steel/spheroidal cast iron
4	Taper bush	EN-GJL-250
5	Fastening bolt	Grade 8.8

# MULTI CROSS RILLO

## Selection of the Coupling Size

The coupling size should be adequate to ensure that the permissible coupling load is not exceeded in any operating condition encountered. For drives which are not subject to periodically recurring high vibratory torques the coupling size selection can be based on the driving torque with reference to the corresponding operating factors.

For specific applications which are subject to periodically recurring high vibratory torques such as combustion engines, piston pumps and compressors, please consult us. Upon request and receipt of your pertinent technical details, we would be pleased to provide a torsional vibration analysis for your specific application.

### In selecting the coupling size the following should be satisfied:

 The **nominal torque of the coupling**  $T_{KN}$  must be taken into account at every temperature and operating load of the coupling, whilst observing the service factors  $S$  (e.g. temperature factor  $S_t$ ) shall be at least equal to the maximum nominal torque on the drive side  $T_{AN}$ ; the temperature in the immediate vicinity of the coupling must be taken into account.

$$T_{KN} \geq T_{AN} \cdot S$$

 The **nominal torque on the drive side**  $T_{AN}$  is calculated with the driving power  $P_{AN}$  and the coupling speed  $n_{AN}$ .

$$T_{AN} [\text{Nm}] = 9550 \frac{P_{AN} [\text{kW}]}{n_{AN} [\text{min}^{-1}]}$$

 For all temperatures in the immediate vicinity of the coupling, the **maximum torque capacity of the coupling**  $T_{K \max}$  must be at least as high as the maximum torque  $T_{\max}$  occurring during operation.

$$T_{K \max} \geq T_{\max}$$

### Permissible ambient temperature range

 For applications at higher ambient temperatures, please consult us

$$-25 \text{ °C} \leq \vartheta \leq +70 \text{ °C}$$

**Nominal torque capacity  $T_{KN}$  in Nm,  $T_{AN}$  in Nm, operating factor SA as per table below**

Service factor: S	Type of operation of the driven machine		
	Load		
Prime mover	Uniform	Medium shock	Heavy shock
Electric motor, turbine, hydraulic motor	1.00	1.75	2.50
Combustion engines 4 - 6 cylinders	1.25	2.00	2.75
Combustion engines 1 - 3 cylinders	1.50	2.25	3.00

**i** Service factor S allows for up to 25 starts per hour. For up to 120 starts per hour, the factor S shall be increased by 0.75

**Uniform loads:** Agitators (light liquids), centrifugal pumps, blowers and fans ( $T \leq 100$  Nm), belt conveyors, screw pumps, filling machines, light-weight centrifuges.

**Medium shock loads:** Agitators (viscous liquids), construction machinery, blowers and fans ( $T \leq 1000$  Nm), mixers, conveyors, planing machines, plastics industry machinery, textile machines, heavy centrifuges.

**Heavy shock loads:** Blowers and fans ( $T \leq 1000$  Nm), running gear, planing machines, sheet metal lines, paper machines, belt conveyors, generators, frequency converters, presses.

**Layout example:**

**Required:** A MULTI CROSS RILLO shaft coupling for driving a planing machine positioned between the motor and the gearbox.

Electric motor  $P_M = 75$  kW, speed  $n_M = 1485$  min<sup>-1</sup>

Power requirement of the planing machine  $P_{AN} = 60$  kW

up to 60 starts per hour

Ambient temperature 25 °C

**Solution:** The MULTI CROSS RILLO coupling should be designed for  $P_{AN} = 60$  kW and with a service factor of  $S = 2.5$  (1.75 as per table plus 0.75 for a starting frequency of more than 25).

$$T_{AN} = 9550 \cdot \frac{60 \text{ kW}}{1485 \text{ min}^{-1}} = 385 \text{ Nm}$$

$$\begin{aligned} T_{KN} &\geq T_{AN} \cdot S \\ T_{KN} &\geq 385 \text{ Nm} \cdot 2.5 = 965 \text{ Nm} \end{aligned}$$

□ The MULTI CROSS RILLO shaft coupling MCR 120 FF at  $T_{KN} = 1350$  Nm should be selected

# MULTI CROSS RILLO

## Assignment to IEC standard motors

### Shaft couplings for IEC Standard motors acc. to DIN 42637/1

The allocation takes into account usual loads, service factor  $S = 1.75$ . For other loads, a design according to "Selection of the proper coupling size" is required. For plants with predominant periodic excitation, the design shall either comply with DIN 740 part 2, or a torsional vibration analysis shall be conducted. The analysis can be provided by us on request.

Motor Size	Motor power at ~3000 min <sup>-1</sup>		Coupling Size MCR	Motor power at ~1500 min <sup>-1</sup>		Coupling Size MCR	Motor power at ~1000 min <sup>-1</sup>		Coupling Size MCR	Motor power at ~750 min <sup>-1</sup>		Coupling Size MCR	Cyl. Shaft end D x L [mm]	
	Power P [kW]	Torque T [Nm]		Power P [kW]	Torque T [Nm]		Power P [kW]	Torque T [Nm]		Power P [kW]	Torque T [Nm]		3000 [min <sup>-1</sup> ]	≤ 1500 [min <sup>-1</sup> ]
56	0.09	0.29	40	0.06	0.38	40	-	-	-	-	-	-	9 x 20	
	0.12	0.38	40	0.09	0.57	40	-	-	-	-	-	-		
63	0.18	0.57	40	0.12	0.76	40	-	-	-	-	-	-	11 x 23	
	0.25	0.80	40	0.18	1.1	40	-	-	-	-	-	-		
71	0.37	1.2	40	0.25	1.6	40	-	-	-	-	-	-	14 x 30	
	0.55	1.8	40	0.37	2.4	40	-	-	-	-	-	-		
80	0.75	2.4	40	0.55	3.5	40	0.37	3.5	40	-	-	-	19 x 40	
	1.1	3.5	40	0.75	4.8	40	0.55	5.3	40	-	-	-		
90 S	1.5	4.8	50	1.1	7.0	50	0.75	7.2	50	-	-	-	24 x 50	
90 L	2.2	7.0	50	1.5	9.6	50	1.1	11.0	50	-	-	-		
100 L	3.0	9.6	50	2.2	14.0	50	1.5	14.0	50	0.75	10	50	28 x 60	
				3.0	19.0	50				1.1	14	50		
112 M	4.0	13.0	50	4.0	25.0	50	2.2	21.0	50	1.5	19	50	38 x 80	
132 S	5.5	18.0	60	5.5	35.0	60	3.0	29.0	60	2.2	28	60		
	7.5	24.0	60											
132 M	-	-	-	7.5	48.0	60	4.0	38.0	60	3.0	38	60	42 x 110	
	-	-	-				5.5	53.0	60					
160 M	11.0	35.0	70	11.0	70.0	70	7.5	72.0	70	4.0	51	70	48 x 110	
	15.0	48.0	70							5.5	70	70		
160 L	18.5	59.0	70	15.0	96.0	70	11.0	105.0	70	7.5	96	70	55 x 110	
180 M	22.0	70.0	70	18.5	118.0	70	-	-	-	-	-	-		
180 L	-	-	-	22.0	140.0	70	15.0	143.0	80	11.0	140	70	55 x 110	
200 L	30.0	96.0	80	30.0	191.0	80	18.5	177.0	80	15.0	191	80		
	37.0	118.0	80				22.0	210.0	80					
225 S	-	-	-	37.0	236.0	90	-	-	-	18.5	236	90	55 x 110	60 x 140
225 M	45.0	143.0	80	45.0	287.0	100	30.0	287.0	100	22.0	280	90		
250 M	55.0	175.0	80	55.0	350.0	100	37.0	353.0	100	30.0	382	100	60 x 140	65 x 140
280 S	-	-	-	75.0	478.0	110	45.0	430.0	110	37.0	471	120	65 x 140	75 x 140
280 M	-	-	-	90.0	573.0	120	55.0	525.0	120	45.0	573	120		
315 S	-	-	-	110.0	700.0	120	75.0	716.0	120	55.0	700	120	65 x 140	80 x 170
315 M	-	-	-	132.0	840.0	140	90.0	860.0	140	75.0	955	140		
315 L	-	-	-	160.0	1019.0	140	110.0	1051.0	140	90.0	1146	140		
	-	-	-	200.0	1273.0	140	132.0	1261.0	140	110.0	1401	160		
355 L	-	-	-	250.0	1592.0	160	160.0	1528.0	160	132.0	1681	160	75 x 140	95 x 170
	-	-	-	315.0	2006.0	160	200.0	1910.0	160	160.0	2037	160		
	-	-	-	-	-	180	250.0	2388.0	180	200.0	2547	160		
400 L	-	-	-	355.0	2260.0	180	315.0	3008.0	180	250.0	3183	180	80 x 170	100 x 200
	-	-	-	400.0	2547.0	180								

# MULTI CROSS RILLO

## Power Ratings

### Coupling details

Speed min <sup>-1</sup>	Size	40	50	60	70	80	90	100	110	120	140	160	180	200	220	250
		Transmissible power [kW]														
100		0.28	0.87	1.58	2.59	4.06	5.16	6.83	9.09	14.2	26.7	41.8	65.4	96.8	120	154
150		0.42	13.1	2.37	3.89	6.09	7.74	10.2	13.6	21.3	40.1	62.7	98.1	145	180	231
200		0.56	1.74	3.16	5.18	8.12	10.3	13.7	18.2	28.5	53.4	83.6	131	194	240	308
300		0.84	2.61	4.74	7.77	12.2	15.5	20.5	27.3	42.6	80.1	125	196	290	360	462
400		1.12	3.48	6.32	10.4	16.2	20.6	27.3	36.4	56.8	107	167	262	387	480	616
500		1.41	4.36	7.88	12.9	20.2	25.7	34.1	45.4	71.4	134	209	327	484	601	767
600		1.68	5.22	9.48	15.5	24.4	31.0	41.0	54.5	85.2	160	251	392	581	720	924
700		1.97	6.10	11.0	18.1	28.4	36.0	47.7	63.6	99.8	187	292	458	678	842	1074
720		2.02	6.26	11.3	18.6	29.2	37.1	49.1	65.4	103	192	301	471	697	866	1104
800		2.25	6.97	12.5	20.7	32.4	41.2	54.5	72.3	114	214	334	523	775	962	1227
900		2.53	7.84	14.1	23.3	36.5	46.3	61.4	81.8	128	241	376	589	872	1082	1380
960		2.69	8.36	15.1	24.8	38.9	49.4	65.5	87.3	137	257	401	628	929	1154	1472
1000		2.81	8.71	15.7	25.9	40.6	51.5	68.2	90.9	143	267	419	655	968	1203	1534
1200		3.37	10.4	18.9	31.0	48.6	61.8	81.8	109	171	321	502	785	1162		
1400		3.93	12.2	22.0	36.2	56.8	72.1	95.5	127	200	375	585	916			
1440		4.04	12.5	22.6	37.2	58.4	74.2	98.3	131	206	385	602	942			
1500		4.21	13.0	23.6	38.8	60.9	77.3	102	136	214	401	627	982			
1800		5.05	15.6	28.3	46.5	73.0	92.7	123	164	257	481					
2000		5.62	17.4	31.5	51.8	81.1	103	136	182	286						
2500		7.02	21.7	39.3	64.7	102	129	145								
2880		8.08	25.0	45.3	74.5	117	149									
3000		8.42	26.1	47.2	77.6	122	155									
3500		9.82	30.4	55.1	90.6											
4000		11.2	34.8	63.0												
4500		12.6	39.1													

**i** The given power ratings apply to the service factor  $S = 1.0$ , see page 10  
 For other service conditions and/or other power ratings, the design should be selected according to page 10

# MULTI CROSS RILLO

## Shaft coupling

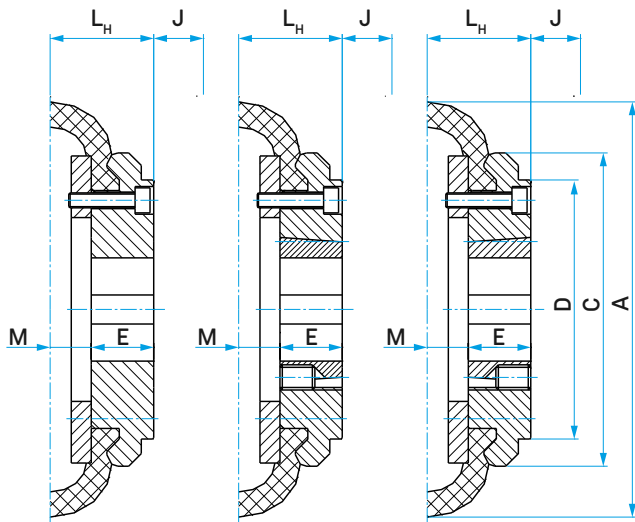

Type B

Type F<sup>\*)</sup>

Type H

Sizes MCR 40 to 60

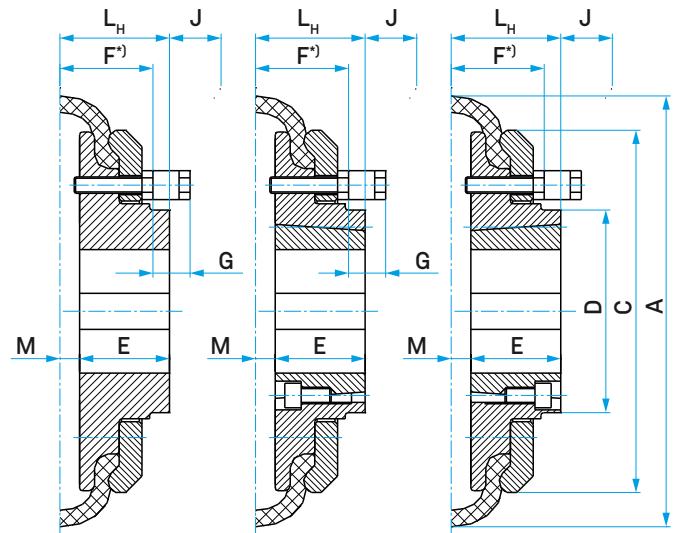

Type B

Type F

Type H

Sizes MCR 70 to 220

 <sup>\*)</sup> Dimensions on request

## Coupling details

Coupling size	Hub type	Taper bush	Max. bore [mm]	A	C	D	L <sub>H</sub>	M	E	G <sup>2)</sup>	J <sup>3)</sup>	Mass <sup>1)</sup>	Moment of inertia <sup>1)</sup>
				[mm]	[mm]	[mm]	[mm]	[mm]	[mm]	[mm]	[mm]	[mm]	[kg]
MCR 40	B	-	32	104	82.0	-	33.0	11.0	22.0	-	-	0.9	0.001
	F	1008	25				33.0		22.0		29	0.9	0.001
	H	1008	25				33.0		22.0		29	0.9	0.001
MCR 50	B	-	38	133	100.0	79	45.0	12.5	32.5	-	-	1.3	0.002
	F	1210	32				37.5		25.0		38	1.3	0.002
	H	1210	32				37.5		25.0		38	1.3	0.002
MCR 60	B	-	45	165	124.5	103	55.0	16.5	38.5	-	-	2.1	0.005
	F	1610	42				41.5		25.0		38	2.1	0.004
	H	1610	42				41.5		25.0		38	2.1	0.004
MCR 70	B	-	50	187	142.0	80	46.5	11.5	35.0	13	-	3.3	0.006
	F	2012	50				44.5		33.0		42	3.3	0.005
	H	1610	42				42.5		31.0		38	3.2	0.005
MCR 80	B	-	60	211	165.0	98	55.0	12.5	42.5	16	-	5.2	0.021
	F	2517	65				58.5		46.0		48	5.2	0.012
	H	2012	50				45.5		33.0		42	4.8	0.014
MCR 90	B	-	70	235	187.0	108	63.5	13.5	50.0	16	-	7.5	0.025
	F	2517	65				59.5		46.0		48	7.4	0.025
	H	2517	65				59.5		46.0		48	7.4	0.025
MCR 100	B	-	80	254	214.0	120	70.5	13.5	57.0	16	-	10	0.073
	F	3020	75				65.5		52.0		55	10	0.042
	H	2517	65				59.5		46.0		48	10	0.047
MCR 110	B	-	90	279	232.0	134	70.5	12.5	58.0	16	-	13	0.105
	F	3020	75				64.5		52.0		55	12	0.064
	H	3020	75				64.5		52.0		55	12	0.064
MCR 120	B	-	100	314	262.0	143	14.5	84.5	70.0	16	-	18	0.163
	F	3525	100			140		80.5	66.0		17	0.123	
	H	3020	75			140		66.5	52.0		55	17	0.127
MCR 140	B	-	130	359	313.0	178	110.0	16.0	94.0	17	-	23	0.452
	F	3525	100				82.0		66.0		67	23	0.373
	H	3525	100				82.0		66.0		67	23	0.373
MCR 160	B	-	140	402	347.0	197	117.0	15.0	102.0	19	-	38	0.737
	F	4030	115				92.4		77.4		80	34	0.594
	H	4030	115				92.4		77.4		80	34	0.594
MCR 180	B	-	150	470	396.0	205	137.0	23.0	114.0	19	-	52	1.302
	F	4535	125				112.0		89.0		89	44	1.078
	H	4535	125				112.0		89.0		89	44	1.078
MCR 200	B	-	150	508	433.0	206	138.0	24.0	114.0	19	-	61	1.847
	F	4535	125				113.0		89.0		89	56	1.592
	H	4535	125				113.0		89.0		89	56	1.592
MCR 220	B	-	160	562	472.0	224	154.5	27.5	127.0	20	-	84	2.829
	F	5040	125				129.5		102.0		92	76	2.431
	H	5040	125				129.5		102.0		92	76	2.431
MCR 250	B	-	190	628	532.0	254	160.5	28.5	132.0	25	-	110	3.645
	F	5040	125				155.5		127.0		-	106	3.645
	H	5040	125				155.5		127.0		-	106	3.645

**i** Dimensions for size F on request

- 1) Mass and moment of inertia for coupling half
- 2) G = Space required for removing and changing the tyre
- 3) J = Space required for fixing and removing the bushes and clamp rings

# MULTI CROSS RILLO

## Coupling with Spacer

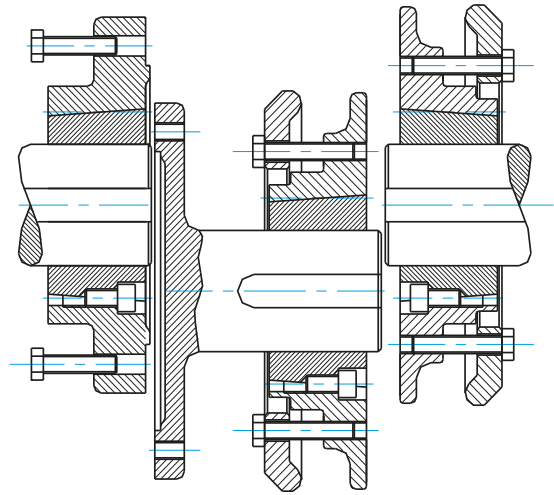
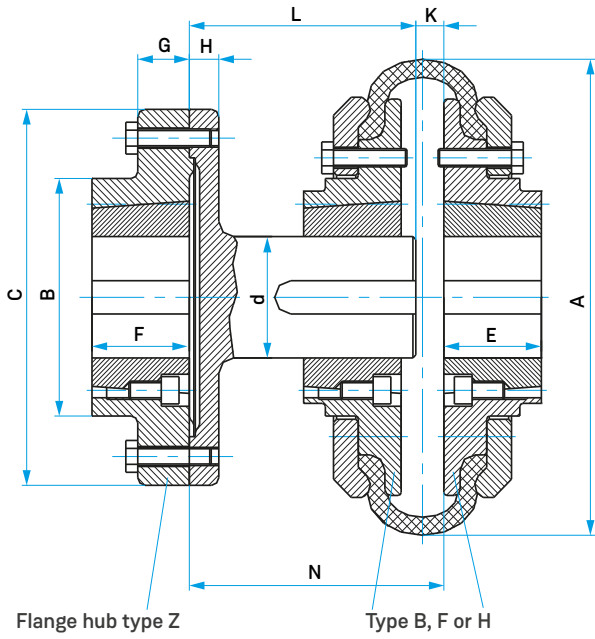



## Coupling details

Coupling size	Taper bush			Bore				A	C	D	d	E				F	L	K	N		Mass <sup>1)</sup>	Moment of inertia <sup>1)</sup>
	Type F	Type H	Type Z	Type B	Type F	Type H	Type Z					Type B	Type F	Type H	Type Z							
				max.	max.	max.	max.									min.	min.	from	to			
				[mm]	[mm]	[mm]	[mm]	[mm]	[mm]	[mm]	[mm]	[mm]	[mm]	[mm]	[mm]	[mm]	[mm]	[mm]	[mm]	[mm]	[kg]	[kgm <sup>2</sup> ]
MCR 40 Z <sup>2)</sup>	1008	1008	1210	32	25	25	32	104	83	118	25	22	22	22	25	65	6	80	-	2.6	0.010	
			1610				40		80	127	32					77	6	100	2.6	0.010		
																88	9	100	113	3.2	0.014	
																128	9	140	150	3.4	0.015	
MCR 50 Z	1210	1210	1610	38	32	32	40	133	80	127	32	32.5	25	25	25	85	9	100	116	3.2	0.014	
																125	9	140	156	3.4	0.015	
MCR 60 Z	1610	1610	1610	45	42	42	40	165	80	127	32	38.5	25	25	25	78	9	100	124	3.2	0.014	
																118	9	100	164	3.4	0.015	
MCR 70 Z <sup>3)</sup>	2012	1610	2517	50	50	42	60	187	125	180	48	35	33	31	45	80	9	100	114	7.8	0.075	
																120	9	140	154	8.4	0.080	
																160	9	180	194	9.0	0.084	
MCR 80 Z	2517	2012	2517	60	65	50	60	211	123	178	48	42.5	46	33	45	78	9	100	117	7.8	0.075	
																116	9	140	158	8.4	0.080	
																156	9	180	198	9.0	0.084	
MCR 90 Z	2517	2517	2517	70	65	65	60	235	123	178	48	50	46	46	45	116	9	140	158	8.4	0.080	
																156	9	180	198	9.0	0.084	
MCR 100 Z	3020	2517	3020	80	75	65	75	254	146	216	60	57	52	46	51	116	9	140	158	14.5	0.202	
																156	9	180	198	15.4	0.212	
MCR 110 Z	3020	3020	3020	90	75	75	75	279	146	216	60	58	52	52	51	116	9	140	158	14.5	0.202	
																156	9	180	198	15.4	0.212	
MCR 120 Z	3525	3020	3525	100	100	75	90	314	178	248	80	70	66	52	63	114	9	140	160	22.2	0.331	
																154	9	180	200	23.8	0.350	
MCR 140 Z	3525	3525	3525	130	100	100	90	359	178	248	80	94	66	66	63	111	9	140	163	22.2	0.331	
																151	9	180	203	23.8	0.350	

**i** Dimensions G and H on request. Further dimensions see MCR shaft couplings on pages 14 - 15

1) Mass and moment of inertia for flange hub type Z and spacer shaft without coupling halves type B, F, or H

2) MCR 40 B - coupling half for spacer shaft required

3) MCR 70 F - coupling half for spacer shaft required

# MULTI CROSS RILLO

## Ordering Information

### The following parts are required for a complete MULTI CROSS RILLO shaft coupling:

- 2 coupling halves, each consisting of hub (type F, H or B), clamp ring, fastening bolts
- 1 rubber tyre
- for hub type F and/or H: specify the taper bush size with bore dimensions; e.g. bush 3020 with bore-Ø 65 mm corresponding to designation: 3020.65 - for hub type B only bore diameter requested

### Ordering example MULTI CROSS RILLO shaft coupling, size MCR 100 FH comprised of:

1x coupling half MCR 100 F (hub, clamp ring and set of fastening bolts)  
 1x coupling half MCR 100 H (hub, clamp ring and set of fastening bolts)  
 1x rubber tyre MCR 100  
 1x taper bush 3020.65 (keyway acc. to DIN 6885/1)  
 1x taper bush 2517.48 (keyway acc. to DIN 6885/1)

### The following parts are required for a complete MULTI CROSS RILLO coupling with spacer:

- 2 coupling halves, each consisting of hub (type F, H or B), clamp ring, fastening bolts
  - 1 rubber tyre
  - for hub type F and/or H: specify the taper bush size with bore dimensions; e.g. bush 2517 with bore-Ø 48 mm corresponding to designation: 2517.48 - for hub type B only bore diameter requested
  - flange hub with specification of the taper bush and the motor shaft diameter, spacer (with indication of the required length L, see pages 14 – 15) and fastening bolts.
- The flange hub is also available without a taper bush but with cylindrical bore on request.

### Ordering example MULTI CROSS RILLO coupling with spacer, size MCR 90 FH Z comprised of:

2x coupling halves MCR 90 F (hub, clamp ring and set of fastening bolts)  
 1x rubber tyre MCR 90  
 1x taper bush 2517.48 (keyway acc. to DIN 6885/1) dimension d, see page 16  
 1x taper bush 2517.48 (keyway acc. to DIN 6885/1) for pump shaft  
 1x spacer shaft with L = 116 mm  
 1x flange hub MCR 90 Z  
 1x taper bush 2517.55 (keyway acc. to DIN 6885/1)

### Available taper bushes

The taper bushes mount MULTI CROSS RILLO couplings onto the shafts in a shrink-fit-like manner. The taper bushes shown are available from stock. Taper bushes are also available with inch bores.

TB-No. | D = metric bores with keyway acc. to DIN 6885/1

1008	9	10	11	12	14	16	18	19	20	22	-	-	-	-	-	-	-	-
1210	11	12	14	16	18	19	20	22	24	25	28	30	32	-	-	-	-	-
1610	14	16	18	19	20	22	24	25	28	30	32	35	38	40	42	-	-	-
2012	14	16	18	19	20	22	24	25	28	30	32	35	38	40	42	45	48	50
2517	16	18	19	20	22	24	25	28	30	32	35	38	40	42	45	48	50	55
3020	25	28	30	32	35	38	40	42	45	48	50	55	60	65	70	75	-	-
3525	35	38	40	42	45	48	50	55	60	65	70	75	80	85	90	-	-	-
4030	40	42	45	48	50	55	60	65	70	75	80	85	90	95	100	-	-	-
4535	55	60	65	70	75	80	85	90	95	100	105	110	-	-	-	-	-	-
5040	70	75	80	85	90	95	100	105	110	115	120	125	-	-	-	-	-	-

# MULTI CROSS RILLO

## Permissible shaft displacement

The indicated values for  $\Delta K_w$  [mm] =  $S_{max} - S_{min}$  (see page 8) correspond to an angular displacement of  $\Delta K_w = 4^\circ$ . This permissible angular shaft displacement is the max. angular misalignment of the coupling halves which may only be fully utilized when no axial and radial misalignments exists. An angular displacement of  $\Delta K_w = 2^\circ$  is permissible when axial and radial misalignments of  $\frac{1}{2} \Delta K_a$  and  $\frac{1}{2} \Delta K_r$  are present.

Observe the operating instructions.

Axial displacement

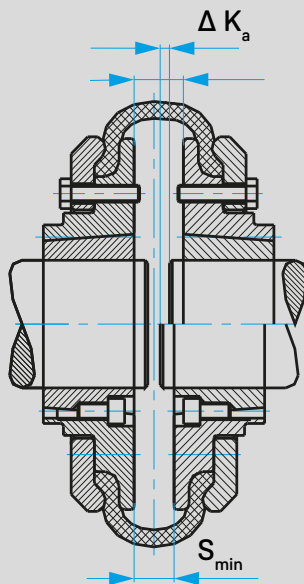

Radial displacement

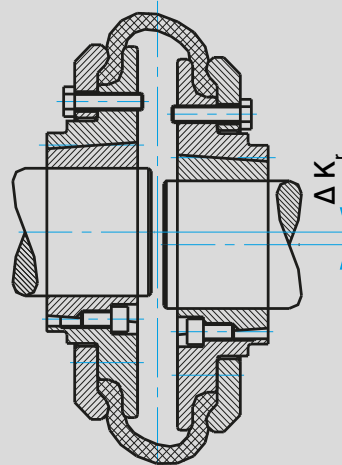

Angular displacement

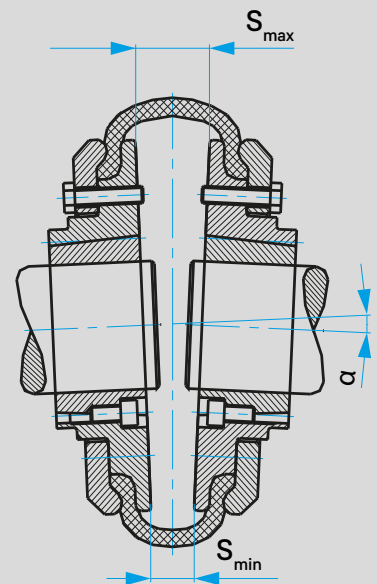

$\Delta K_a, \Delta K_r, \Delta K_w$  see General Technical Data page 8

# MULTI CROSS RILLO

## Data Required for Coupling Size Selection

From (stamp):	Contact person: _____
	Department: _____
	Telephone: _____
	Fax: _____

**Dipl. - Ing. Herwarth Reich GmbH**  
**Vierhausstrasse 53**  
**44807 Bochum**



### Drive side:

Prime mover:  Diesel- /  Hydraulic- /  E-Motor  
 Others: \_\_\_\_\_  
 Nominal power: \_\_\_\_\_ kW at speed: [min<sup>-1</sup>] \_\_\_\_\_  
 Speed range: from \_\_\_\_\_ to \_\_\_\_\_ [min<sup>-1</sup>]  
 max. starting/shock torque: \_\_\_\_\_ [Nm]

### Enquiries Orders

\_\_\_\_\_

\_\_\_\_\_

### General system details:

Place of installation/environmental conditions: \_\_\_\_\_  
 Load:  uniform  medium  heavy  
 Ambient temperature at the coupling: \_\_\_\_\_ [°C]  
 Daily period of operation: \_\_\_\_\_ Hours/day  
 Starting frequency: \_\_\_\_\_ per day  
 Shaft displacement:  
 $\Delta K_a$ : \_\_\_\_\_ [mm]/ $\Delta K_r$ : \_\_\_\_\_ [mm]/ $\Delta K_w$ : \_\_\_\_\_ [°]

### Output side:

Driven machine: \_\_\_\_\_  
 Nominal power: \_\_\_\_\_ [kW]  
 max. load torque: \_\_\_\_\_ [Nm]  
 in case of uneven torque load:  
 from \_\_\_\_\_ to \_\_\_\_\_ [Nm]

### Balancing: yes no

Balancing speed: \_\_\_\_\_ [min<sup>-1</sup>]/grade: G \_\_\_\_\_  
 Balancing with keyway:  yes  no  
 Annotations: \_\_\_\_\_  
 \_\_\_\_\_

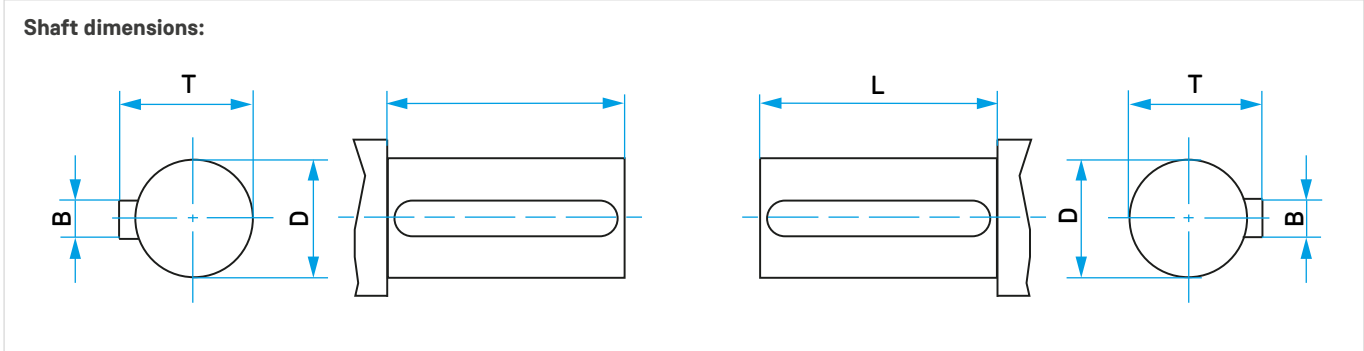

**Further coupling design specifications** (e.g. with brake drum/brake disc/material):

\_\_\_\_\_

\_\_\_\_\_

**Further details of the complete system/principle sketch of installation situation:**

\_\_\_\_\_

\_\_\_\_\_



# MULTI CROSS RILLO

Notes

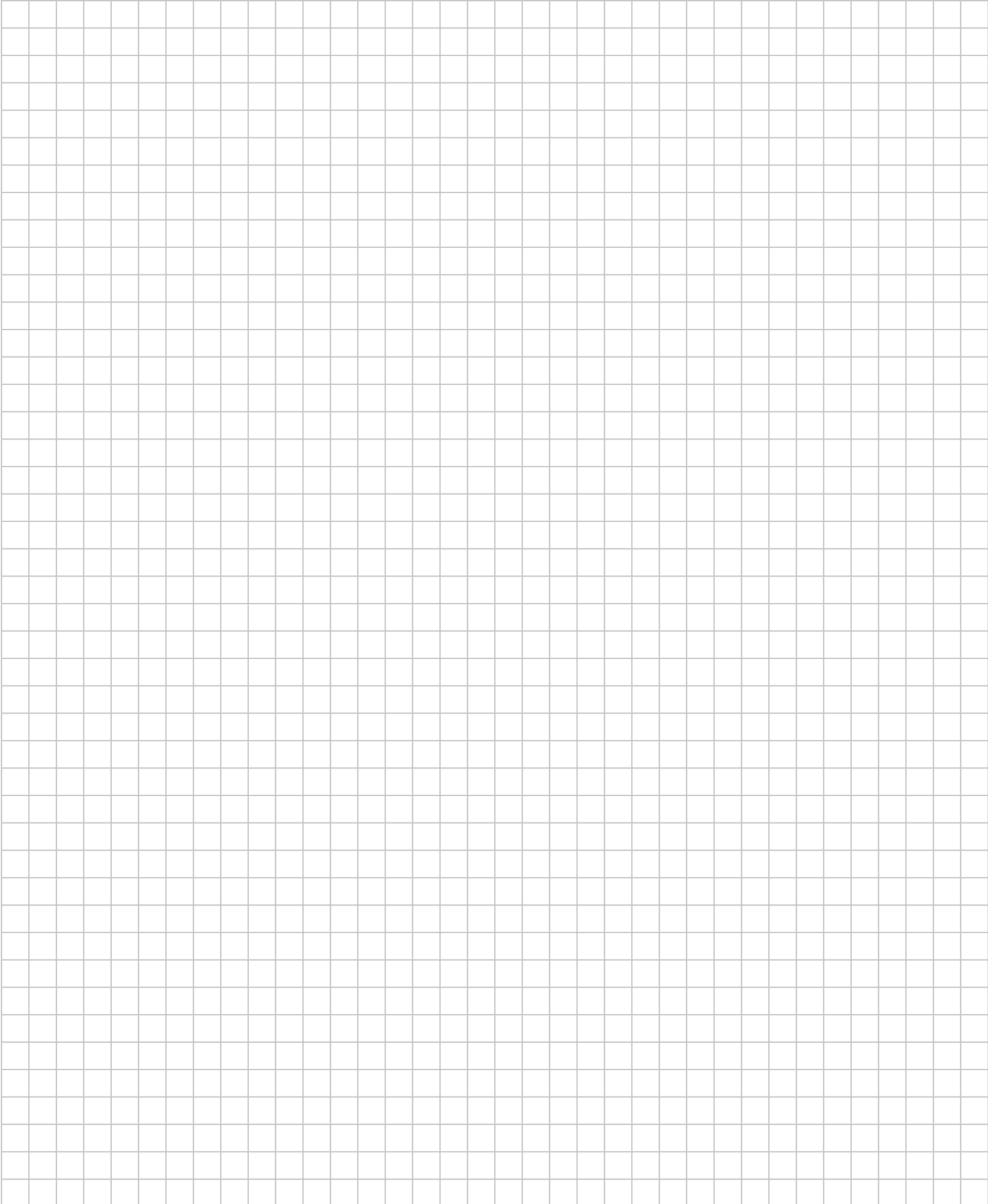
A large grid of graph paper for taking notes, consisting of 20 columns and 40 rows of small squares.

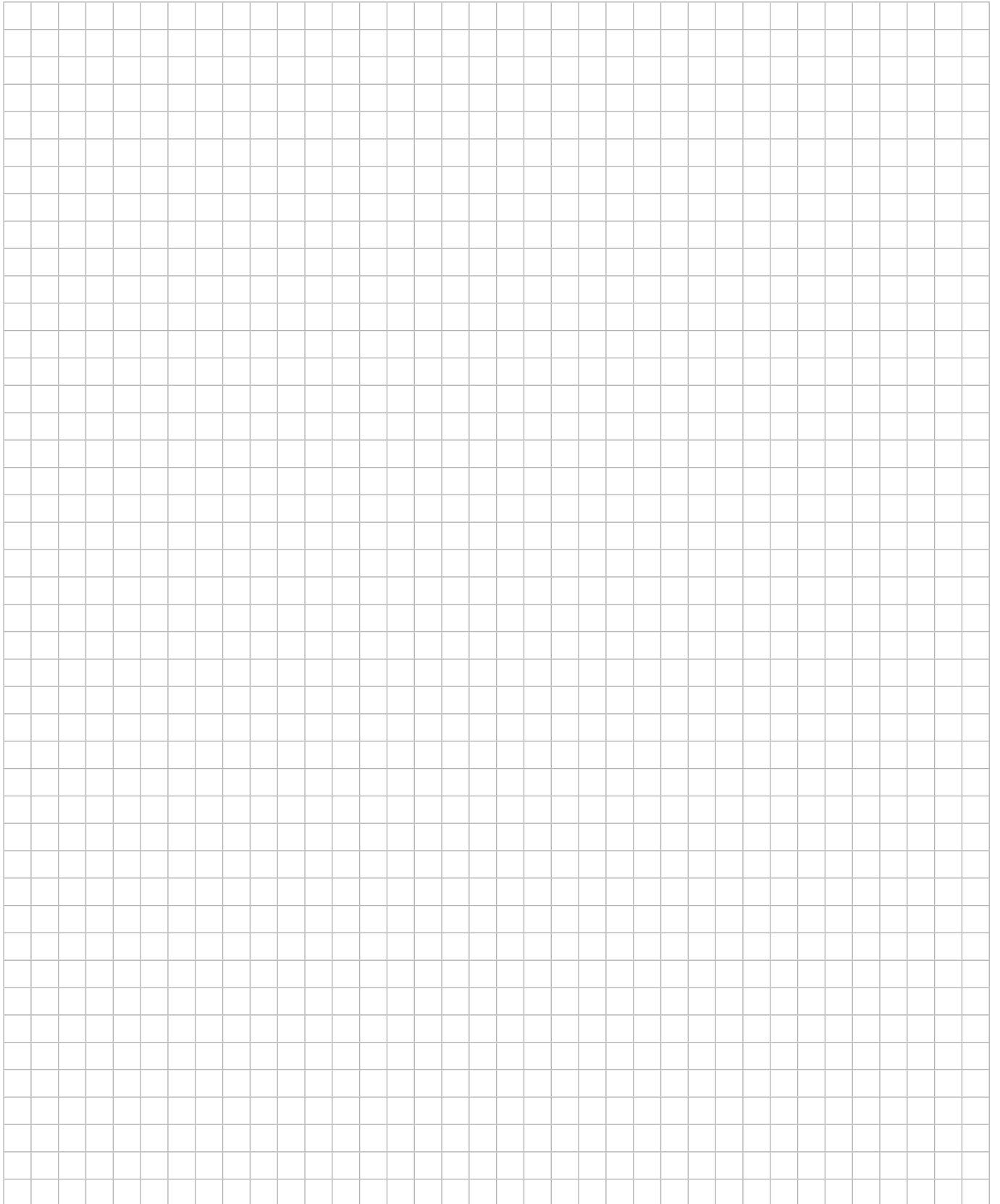



## MULTI CROSS RILLO

SIMPLY **POWERFUL.** ————— □



### Industrial solutions:

- ⚡ Power generation
- 🚛 Mobile applications
- 💡 Test benches
- 🔧 Pumps & compressors
- ⚙️ Industry
- ⚓ Ship & port engineering

### Headquarter:

Dipl.-Ing. Herwarth Reich GmbH  
Vierhausstrasse 53 · 44807 Bochum  
☎ +49 234 95916-0  
✉ [mail@reich-kupplungen.com](mailto:mail@reich-kupplungen.com)  
🌐 [www.reich-kupplungen.com](http://www.reich-kupplungen.com)

### Copyright ISO 16016 to be observed:

The reproduction, distribution and utilisation of this document as well as the communication of its contents to others without explicit authorisation is prohibited. Offenders will be held liable for the payment of damages. All rights reserved in the event of the grant of a patent, utility model or design. © REICH - Dipl.- Ing. Herwarth Reich GmbH

### March 2020 edition

The present MULTI CROSS RILLO catalogue edition renders parts of the previous MULTI CROSS RILLO catalogues obsolete. All dimensions in millimetres. We reserve the right to change dimensions and/or design without prior notice. Texts and illustrations, dimensional and performance data have been compiled with the utmost care. There is no guarantee, however, that the information is accurate; in particular, there is no guarantee that products will match the illustrations in terms of technology, colour, shape and configuration or that the products will correspond to the proportions of the illustrations. We also reserve the right to make changes due to printing errors or mistakes.